



GE VERNOVA

PROFICY® SOFTWARE & SERVICES

ORCHESTRATION HUB

User Guide

Proprietary Notice

The information contained in this publication is believed to be accurate and reliable. However, GE Vernova assumes no responsibilities for any errors, omissions or inaccuracies. Information contained in the publication is subject to change without notice.

No part of this publication may be reproduced in any form, or stored in a database or retrieval system, or transmitted or distributed in any form by any means, electronic, mechanical photocopying, recording or otherwise, without the prior written permission of GE Vernova. Information contained herein is subject to change without notice.

© 2024 GE Vernova and/or its affiliates. All rights reserved.

Trademark Notices

“VERNOVA” is a registered trademark of GE Vernova. “GE VERNOVA” is a registered trademark of GE Aerospace exclusively licensed to GE Vernova. The terms “GE” and the GE Monogram are trademarks of GE Aerospace and are used with permission.

Microsoft® is a registered trademark of Microsoft Corporation, in the United States and/or other countries.

All other trademarks are the property of their respective owners.

We want to hear from you. If you have any comments, questions, or suggestions about our documentation, send them to the following email address:
doc@ge.com

Table of Contents

- Overview 1
- Introduction 1
 - Conceptual Overview 1
- Design Flow..... 2
 - L4 Systems 2
 - Orchestration Hub..... 2
 - L2 Systems 3
- Orchestration Hub Flow 3
 - Step 1..... 3
 - Step 2..... 3
- Enterprise View Flow..... 4
 - Step 1..... 4
 - Step 2..... 5
 - Step 3..... 5
 - Step 4..... 6
 - Step 5..... 6
 - Step 6..... 9
 - Step 7..... 10
 - Step 8..... 11
 - Step 9..... 11
 - Step 10..... 12
 - Step 11..... 13
 - Step 12..... 14
 - Step 13..... 15
- Plant Connect Flow 15
 - Step 1..... 15
 - Step 2..... 16
 - Step 3..... 16
 - Step 4..... 17
 - Step 5..... 17

Step 6.....	18
Step 7.....	18
Step 8.....	19
Step 9.....	19
Step 10.....	20
Step 11.....	21
Step 12.....	21
Variance Management Flow.....	22
Step 1.....	22
Step 2.....	22
Step 3:.....	23
Step 4:.....	23
Customization of Column Names.....	26
Step 1.....	26
Step 2.....	27
Localization.....	28

Overview

The manufacturing industry, especially process manufacturing, is constantly trying to differentiate and innovate with an intent to maintain and grow their consumer base. This drives the need for constant innovation which introduces a high degree of variability in the daily manufacturing process. Most of the manufacturing customers struggle to manage this variability effectively and that becomes a cause for inefficiencies in their production. The greater the number of products and/or regulatory standards that these manufacturing facilities have to deal with, the larger the problem of being out of synch with the latest product manufacturing information.

Introduction

Proficy Orchestration Hub enables manufacturing customers to stay in synch with the constant updates to product manufacturing information. The solution provides out-of-the-box tools to unify product manufacturing information from disparate data systems like ERP and PLM, transforms and organizes this raw business-oriented information into production-ready formats like recipes and specifications, and orchestrates the information across the customer's factory floor systems at a single site or multiple facilities.

Proficy Orchestration Hub 2023 focuses on the first foundational theme of Manufacturing Product Data Management (mPDM). The 2023 release of Orchestration Hub focuses on the following customer problems to solve: production delays, errors and rework due to lack of up-to-date product data in production systems; quality variability due to ad-hoc modifications and lack of visibility into the cause of modifications; and the inability to reduce non-productive time due to manual efforts trying to execute standard production work

Conceptual Overview

The primary functional objective of Orchestration Hub software is to have a platform that allows you to integrate Level4 systems like ERP, PLM, SAP, ORACLE etc., with Level2 systems like Plant Applications, iFIX, CIMPLICITY and Batch, so that they can synchronize with the latest / updated manufacturing data (classified as master data) available in the L4 systems with that in the L2 systems. One of the primary success criteria for Orchestration Hub software is to be independently installable and configurable and to be able to connect with any kind of L4 and L2 systems supporting multiple protocols for connection (SOAP/REST/ODATA/Native SQL, etc.), without major development work.

Design Flow

The following figure details the design/flow/route of Orchestration Hub.

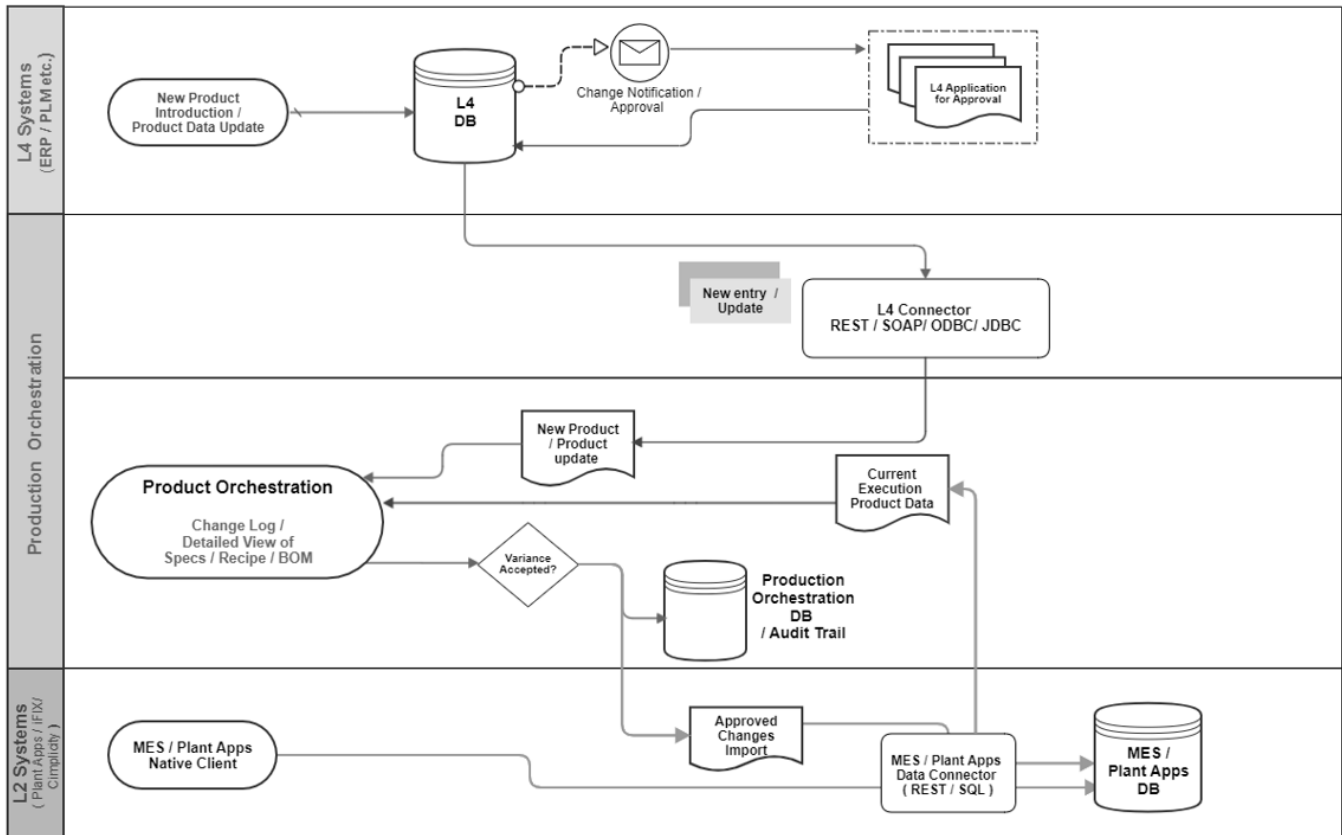

L4 Systems

Under the L4 system, any update on a new product introduction or update on existing products and has L4 application approval comes to Orchestration Hub.

Orchestration Hub

Orchestration Hub catches the new entry using the L4 Connector, and then the same goes to our application with all the logs, detailed view of our recipe/specifications if the variance is approved and then accepted the changes go to the MES/Plant Applications native client.

L2 Systems

In the L2 System, Plant Applications approves change reports directed towards the MES/Plant Applications data connector and then lands in the Plant Applications database.

Orchestration Hub Flow

Step 1

As a Plant Overseer/Supervisor, launch the given URI of Application after being alerted about changes to Product Master Data: <https://decibel po/uaa/login>

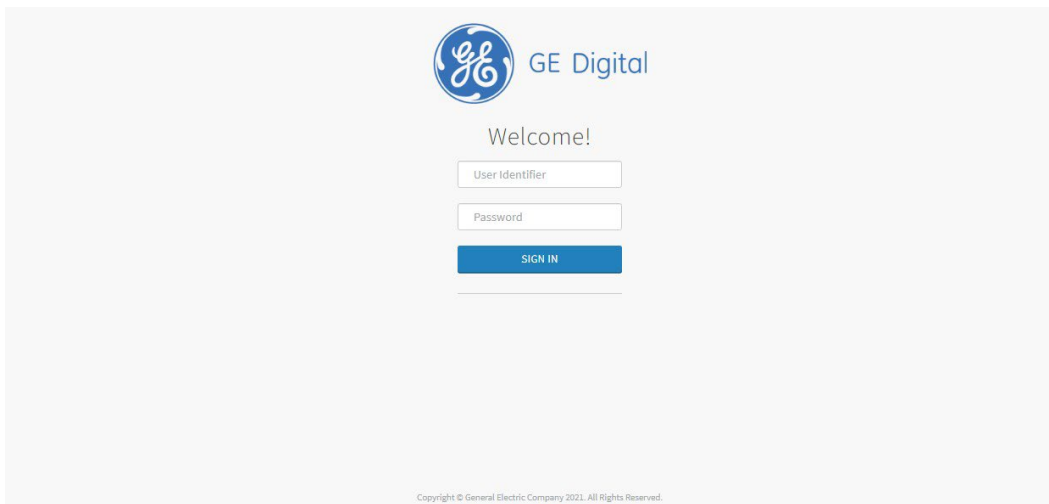

Step 2

Enter the accurate required credentials to get access to the Application.

User Identifier: <<Valid User>>

Password: - <<Valid Password>>



Welcome!

comxclient

...

SIGN IN

Enterprise View Flow

Step 1

When the application launches, you should see all 3 Grids: Expiration, New Products and current Products Updates.

The screenshot displays the 'Orchestration Hub' interface. It features a dark sidebar on the left with navigation icons. The main content area is divided into three sections, each with a search bar and a table of data.

New Products (1)

STATUS	CHANGETYPE	PRODUCT	LOCATION	PRODUCT FAMILY	ACTION
Approved	New Product	Dark Chocolate	New York	Select a Family...	Add

Expiration (1)

STATUS	CHANGETYPE	SPEC NAME	SPEC NUMBER	PRODUCT ID	EXPIRATION DATE	LOCATION	ACTION
Inactive	Recipe	White Chocolate	5012833-002	12572	09/23/2021	New York	Update

Product Updates (1)

STATUS	CHANGETYPE	PRODUCT FAMILY	PRODUCT	PRODUCT ID	LOCATION	ACTION
Approved	Recipe/Spec	External-Product	White Chocolate	12572	New York	Review

Step 2

On the home page, if you identify that the Expiration Date of Spec needs to get updated, click the Update button. A message box appears. Click Accept to continue. Upon a successful update the "Expiration Date Updated Successfully "message appears.

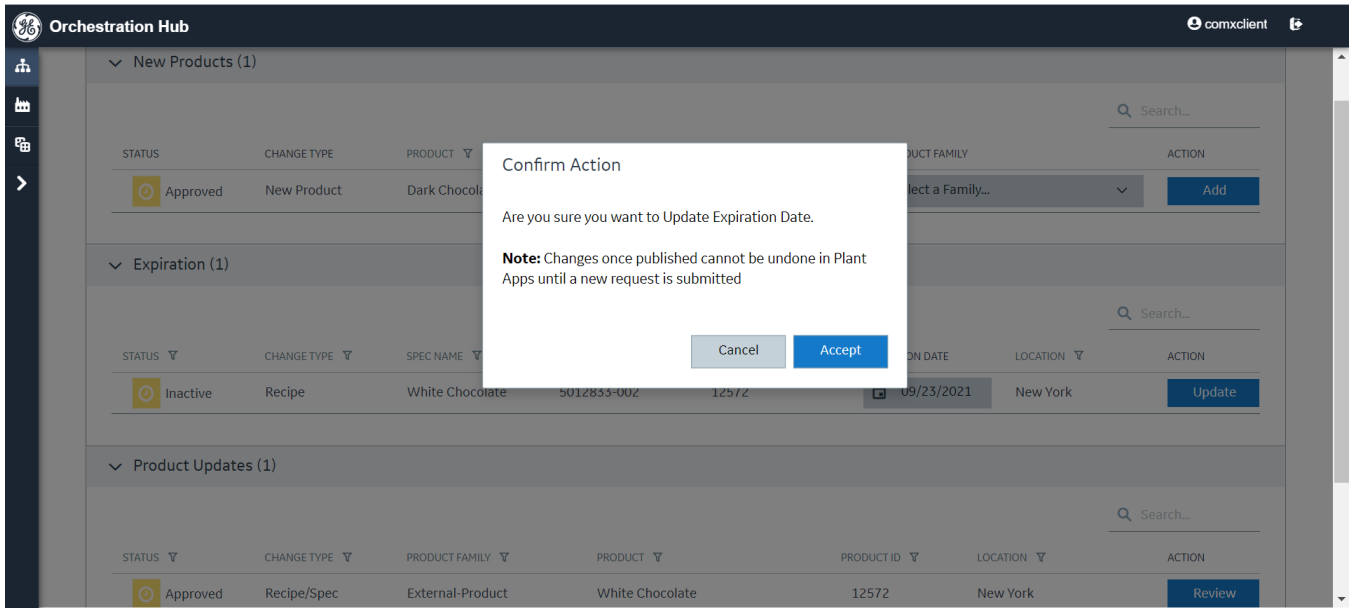

Step 3

However, if the Product master data displays that a new Product has to be added in a consolidated product record on home screen's New Product grid, select decide family for the new Product and then Add that Product which previously was not reflected in Plant Applications.

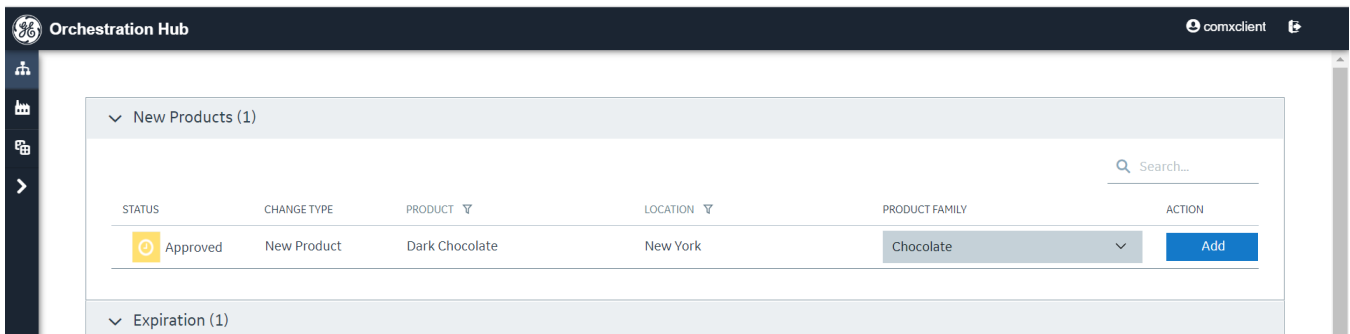

Step 4

If a record appears where there are updates required in an existing product, then as a supervisor, click Review to proceed, and all the details display under the Summary tab in a compared view of the current information versus the existing product that was setup in Plant Applications.

The screenshot displays the 'Orchestration Hub' interface for a 'Product Update - 12572'. The interface includes a navigation sidebar on the left, a top header with 'Orchestration Hub' and 'comoxclient', and a main content area. The main content area has a 'Publish Accepted Changes' button and a 'VARIANCE LOG' icon. Below this, there are tabs for 'Summary', 'Specs', 'BOM', 'Route', and 'Recipe'. The 'Summary' tab is active, showing '23 Changes'. A table lists the changes with columns: AREA, ITEM, PARAMETER, CHANGE, CURRENT VALUE IN PA, NEW VALUE FROM ERP, and COMMENTS. The table contains five rows of data, each with a 'View' button. A pagination bar at the bottom shows page 1 of 5.

AREA	ITEM	PARAMETER	CHANGE	CURRENT VALUE IN PA	NEW VALUE FROM ERP	COMMENTS
Spec	WEB_THICKNESS - High	Target Value	Value modification	35.00767676	3.00	View
Spec	WEB_THICKNESS - High	Lower Reject	Value modification	30		View
Spec	WEB_THICKNESS - High	Upper Reject	Value modification	50		View
Spec	CELL_DENSITY - High	Target Value	Value modification	35.00767676	1.8	View
Spec	CELL_DENSITY - High	Lower Reject	Value modification	30		View

Step 5

You can verify the Limit of every specification. For example: what is their lower limit, and upper limit with the Target that was previously in plant and the current Target that has been proposed by Our Master App. You can select the right combination of properties and specifications from the drop-down values to update the specification values.

The Affected products icon provides the details of the products which are associated with the same property- characteristic combination as displayed in the UI.

Orchestration Hub comxclient

< Back Product Update - 12572 Publish Accepted Changes

STATUS: PRODUCT: 12572 PRODUCT ID: 12572 LOCATION: Hyderabad VARIANCE LOG:

Summary **Specs** BOM Route Recipe Show All Values

PROPERTY	SPECIFICATIONS	ERP VALUE	AFFECTED PRODUCTS	Accept all	
%Sugar	High	WEB_THICKNESS			
SPEC LIMITS	CURRENT VALUE OF PLANT APPS	NEW VALUE FROM ERP	COMMENTS	ACTION	
Target	35.00767676	3.00			
Lower Reject	30				
Upper Reject	50				

10 15 20 < 1 >

When clicking the eye icon shown as shown below, you can see the affected products.

Orchestration Hub comxclient

< Back Product Update - 12572 Publish Accepted Changes

STATUS: PRODUCT: 12572 PRODUCT ID: 12572 LOCATION: Hyderabad VARIANCE LOG:

Summary **Specs** BOM Route Recipe Show All Values

PROPERTY	SPECIFICATIONS	ERP VALUE	AFFECTED PRODUCTS	Accept all	
%Sugar	High	WEB_THICKNESS			
SPEC LIMITS	CURRENT VALUE OF PLANT APPS	NEW VALUE FROM ERP	COMMENTS	ACTION	
Target	35.00767676	3.00			
Lower Reject	30				
Upper Reject	50				

10 15 20 < 1 >

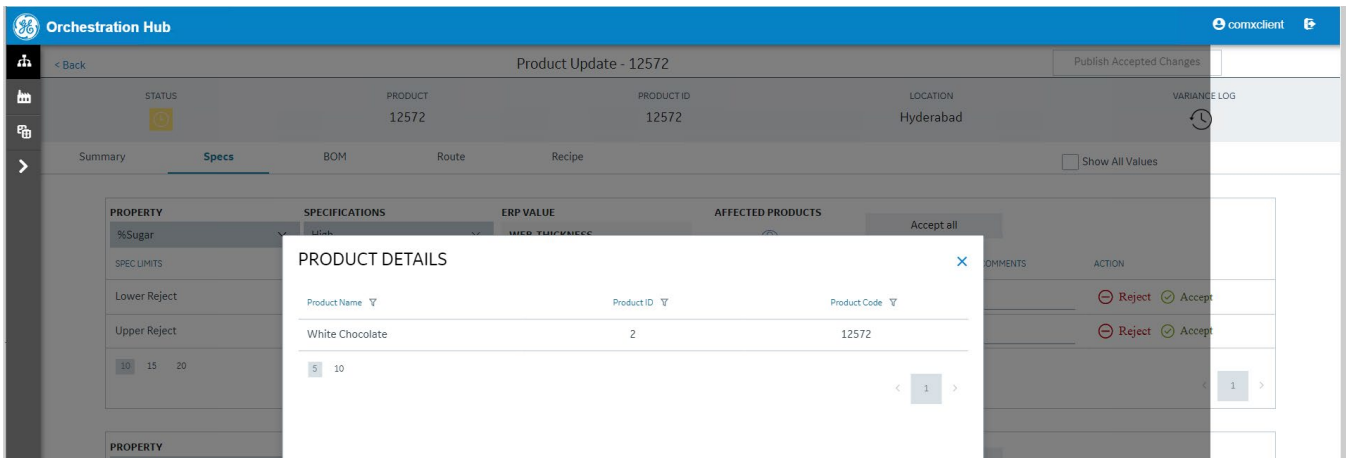

You can reject or accept the changes in the Spec by providing comments. When accepting the changes, a message appears requesting a confirmation of the accepted changes. A comment is mandatory for rejecting a change.

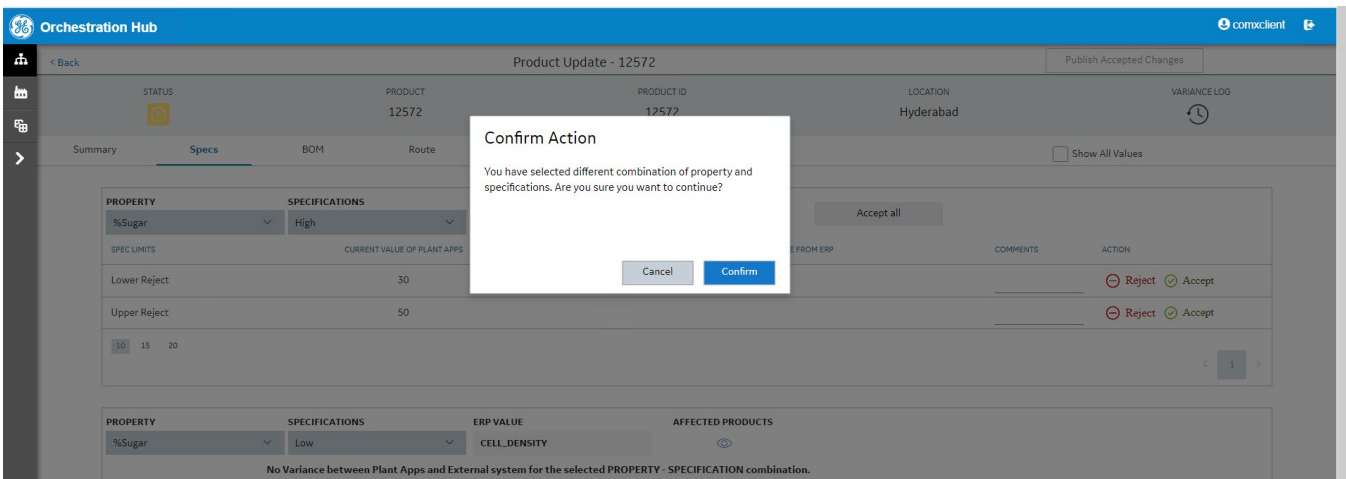

You can click Accept all and all the changes in a property gets accepted.

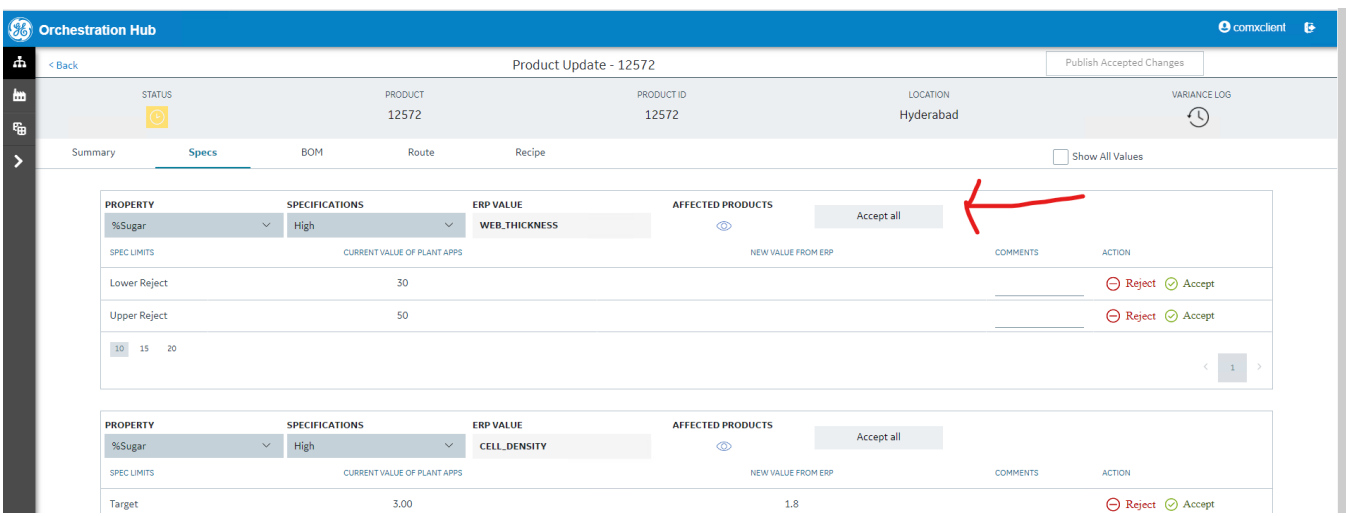

Orchestration Hub Product Update - 12572 Publish Accepted Changes

STATUS: PRODUCT: 12572 PRODUCT ID: 12572 LOCATION: Hyderabad VARIANCE LOG:

Summary Specs BOM Route Recipe Show All Values

PROPERTY	SPECIFICATIONS	ERP VALUE	AFFECTED PRODUCTS	COMMENTS	ACTION
%Sugar	High	WEB_THICKNESS			Undo
SPEC LIMITS CURRENT VALUE OF PLANT APPS NEW VALUE FROM ERP					
Lower Reject	30				Undo
Upper Reject	50				Undo
10 15 20 < 1 >					

You can click on Show all value to see all the available specification values for a property.

Orchestration Hub Product Update - 12572 Publish Accepted Changes

STATUS: PRODUCT: 12572 PRODUCT ID: 12572 LOCATION: Hyderabad VARIANCE LOG:

Summary Specs BOM Route Recipe Show All Values

PROPERTY	SPECIFICATIONS	ERP VALUE	AFFECTED PRODUCTS	COMMENTS
%Sugar	High	WEB_THICKNESS		
SPEC LIMITS CURRENT VALUE OF PLANT APPS NEW VALUE FROM ERP				
Target	3.00		3.00	
Lower Reject	30		<input type="text"/>	
Upper Reject	50		<input type="text"/>	
Lower Entry				
Lower Warning	35.00		35.00	
Lower User				
Upper User				
Upper Warning	55.00		55.00	
Upper Entry				
Lower Control				
10 15 20				

Step 6

The Bills of Materials IN short BOM shall display the spec/recipe that are needed to be updated and need to be reviewed.

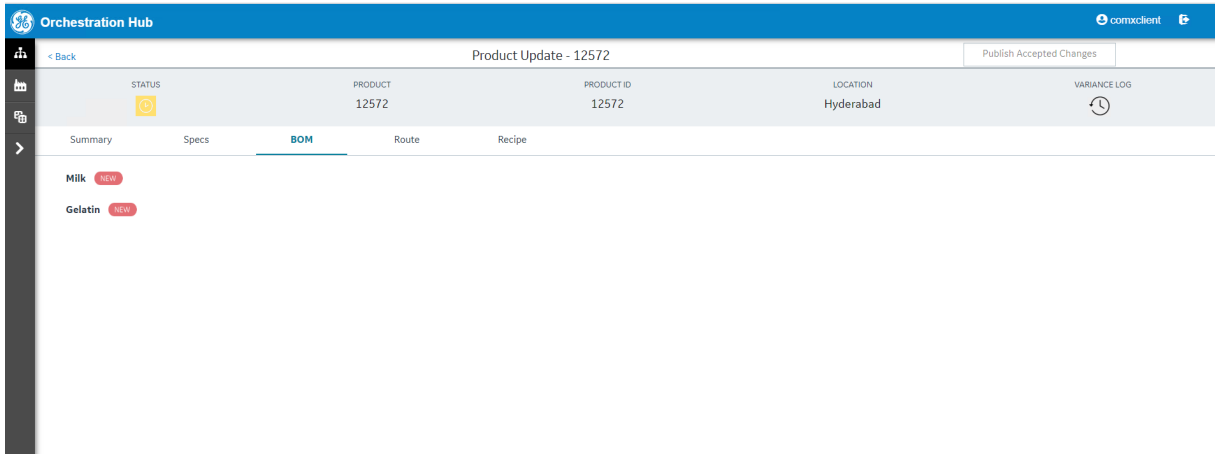

Step 7

When you switch to the recipe Tab, you can determine whether to accept the new changes that have been proposed by SAP/ERP/Oracle etc. system and update against our existing Product details in Plant Applications. After you accept/reject these differences of changes, the same data would be reflected/ get updated in Plant Applications for future operation.

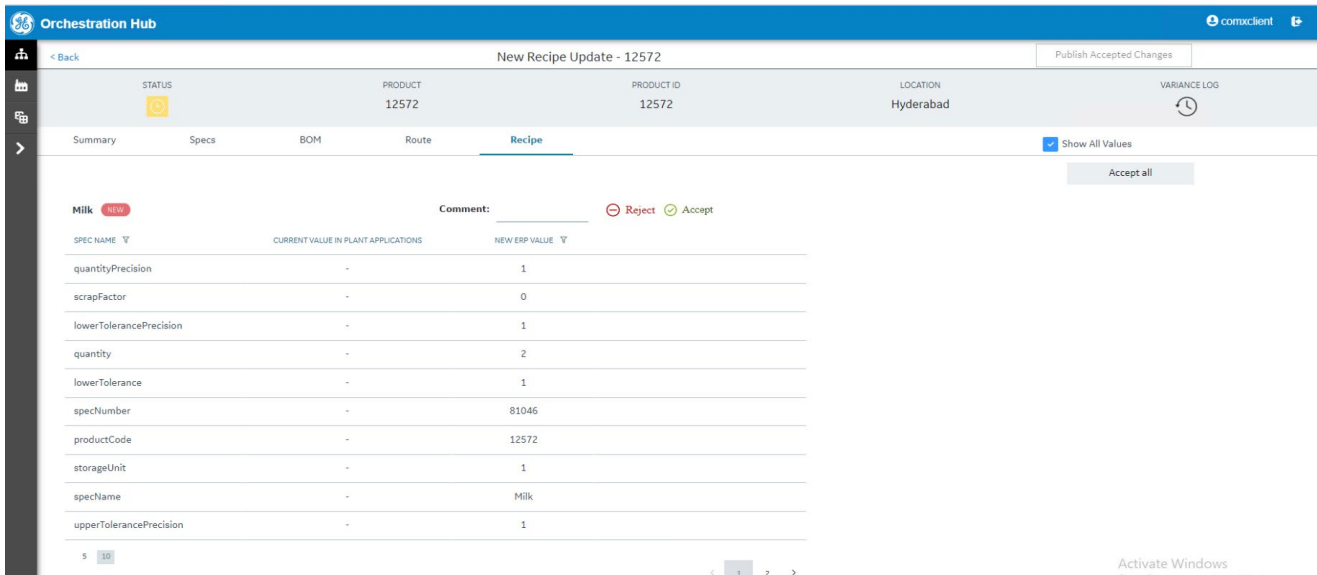

Step 8

In Route, you can configure the channel that the Product line follows in sequences and post/adjust our route based on updates.

The screenshot shows the 'Route' configuration page in the Orchestration Hub. The main header displays 'Product Update - 12572' and a 'Publish Accepted Changes' button. Below this, there are tabs for 'Summary', 'Specs', 'BOM', 'Route', and 'Recipe'. The 'Route' tab is active, showing the following details:

- General:** Path Code: FA_PathCode, Description: FA_Path. Production on this path should count to line production: True. This Execution Path is controlled by a schedule: True.
- Path Units:** A table with columns: Execution Path Unit Id, Is Schedule Point, Unit Name, and Unit Order.

Execution Path Unit Id	Is Schedule Point	Unit Name	Unit Order
1	<input type="checkbox"/>	Tube_Packing	1
2	<input checked="" type="checkbox"/>	Mixing	2
3	<input type="checkbox"/>		3
4	<input type="checkbox"/>		4
- Path Products:** A table with columns: PRODUCT ID, PRODUCT CODE, and DESCRIPTION.

PRODUCT ID	PRODUCT CODE	DESCRIPTION
2	12572	White Chocolate

Step 9

After you accept/reject the details you can publish those changes and review them in Review Changes for Product details screen. You can then publish them by clicking the Publish button.

The screenshot shows the 'Review Changes for 12572' page in the Orchestration Hub. The main header displays 'Review Changes for 12572' and a 'Publish' button. Below this, there is a summary table:

REQUEST DATE	TOTAL ITEMS	ACCEPTED ITEMS	REJECTED ITEMS
06-27-2022	6	5	1

Below the summary, there are two sections: 'Accepted Changes' and 'Rejected Changes'. Each section contains a table with columns: AREA, ITEM, CHANGE, CURRENT VALUE IN PLANT APPS, NEW VALUE FROM ERP, and COMMENTS.

Accepted Changes:

AREA	ITEM	CHANGE	CURRENT VALUE IN PLANT APPS	NEW VALUE FROM ERP	COMMENTS
Recipe	Milk-All Items	Addition Of Item	--	--	
Recipe	Gelatin-All Items	Addition Of Item	--	--	
Spec	%Sugar-High-Lower Reject	Value Modification	30		
Spec	%Sugar-High-Upper Reject	Value Modification	50		
Spec	%Sugar-Low-Target	Value Modification	1.8	Round	

Rejected Changes:

AREA	ITEM	CHANGE	CURRENT VALUE IN PLANT APPS	NEW VALUE FROM ERP	COMMENTS
Spec	%Sugar-Medium-Target	Value Modification	Round	1.8	can not accept

Step 10

If e-signature is configured , once user tries to publish e-signature pop-up window will open .

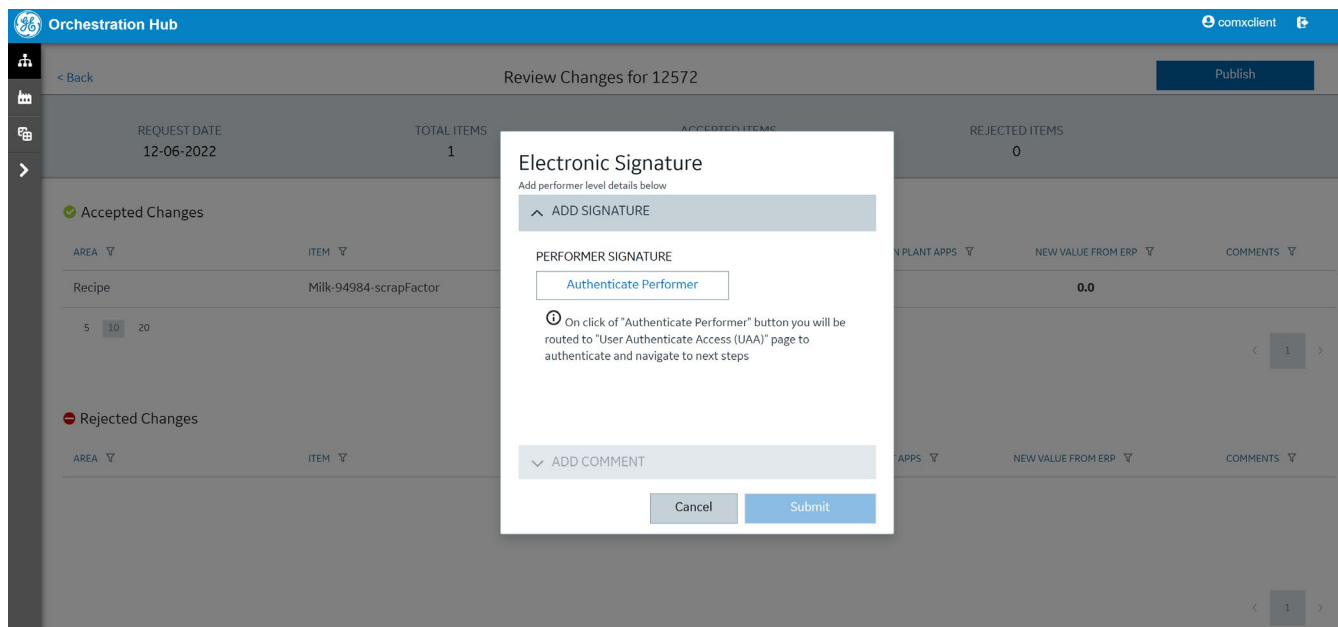

Step 11

Click on Authenticate Performer and give correct credentials to do e-signature . It will take you back to original page .



GE Digital

Welcome!

comxclient

....

SIGN IN

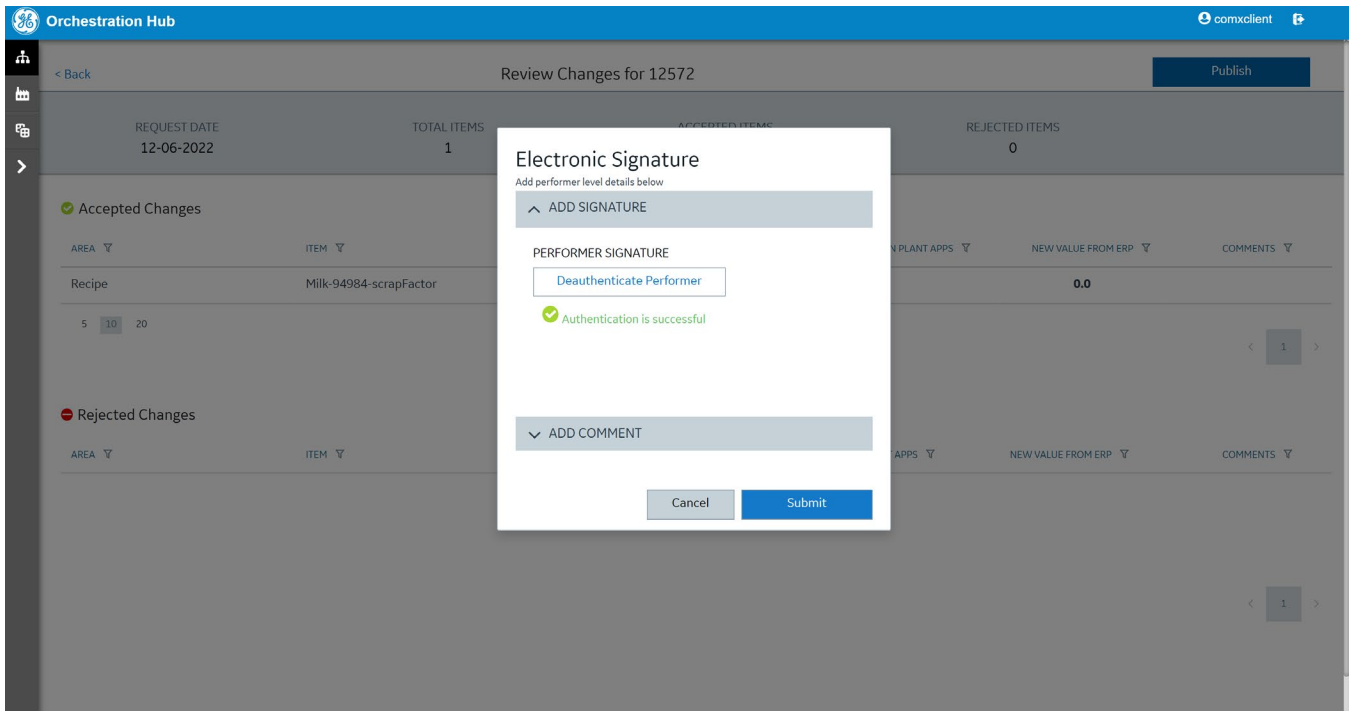

Step 12

After publishing, a success message appears: " All the accepted changes has been successfully published" and this indicates that updates that have been reviewed and accepted/rejected and are now reflected in our Plant Applications system.

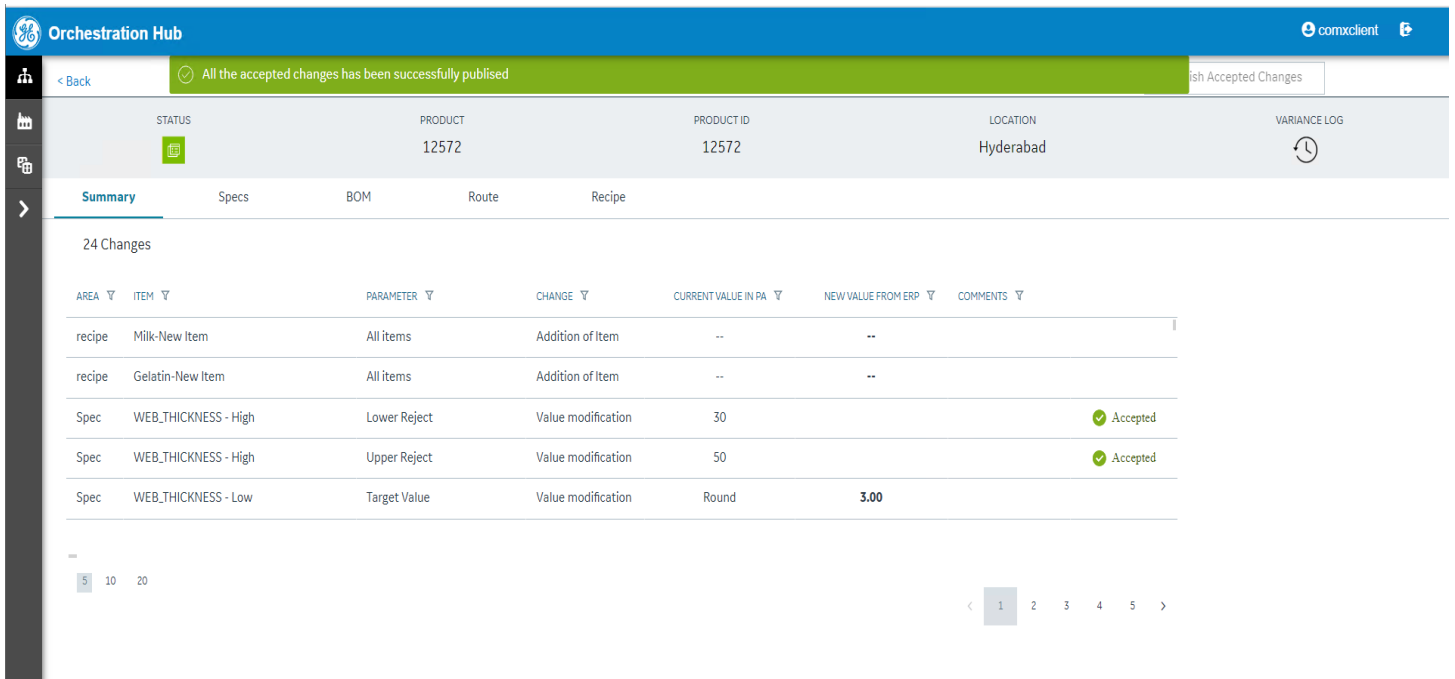

Step 13

After you select updated products and review them by clicking the variance log icon, you may see and track on Variance logs screen.

Product Description	Change Type	Action	Choose Date Range
12572	ALL	ALL	Jun 26, 2022 - Jun 27, 2...

Proda...	Product Descr...	Action	Modified By	Date	Change Ty...	Parameter	Item	Previou...	Change...	Location	Comments
12572	12572	Accepted	comxclient	6/27/2022	SPEC	target	High-%Su...	35.0076...	3.00	Hyderab...	
12572	12572	Accepted	comxclient	6/27/2022	SPEC	lowerReje...	High-%Su...	30		Hyderab...	
12572	12572	Accepted	comxclient	6/27/2022	SPEC	upperReje...	High-%Su...	50		Hyderab...	
12572	12572	Accepted	comxclient	6/27/2022	SPEC	target	Low-%Sug...	3.00	1.8	Hyderab...	
12572	12572	Accepted	comxclient	6/27/2022	SPEC	target	Medium...	3.00		Round	Hyderab...

Plant Connect Flow

Step 1

Select Plant Connect in the Left Navigation Menu to enter the Plant Connect Application.

After entering the Application, All Product Properties appear configured in Proficy Plant Applications.

Product Properties	Plant Central Specification Management
Search...	Activity Logs Publish Changes
Displaying 1-4/4	Spec Limits
> %Sugar	<input type="checkbox"/> L-Entry <input type="checkbox"/> L-Reject <input type="checkbox"/> L-Warn <input type="checkbox"/> L-User <input type="checkbox"/> Target <input type="checkbox"/> U-User <input type="checkbox"/> U-Warn <input type="checkbox"/> U-Reject <input type="checkbox"/> U-Entry <input type="checkbox"/> L-Control <input type="checkbox"/> T-Control <input type="checkbox"/> U-Control
> PerformanceRates	
> PP_Process Parameters	
> PP_Quality Parameters	

Step 2

You can select any of the Product Properties on the left menu to see all its characteristics in a hierarchical manner.

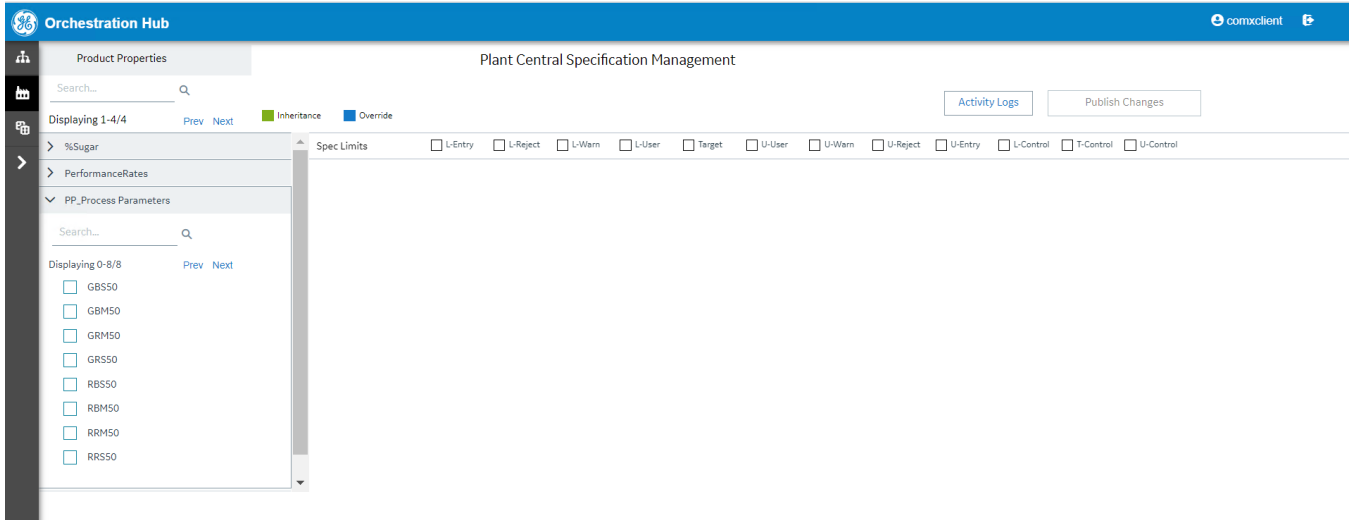

Step 3

You can select any characteristics on the left menu. The spec Limits on the center top show the respective specification values.

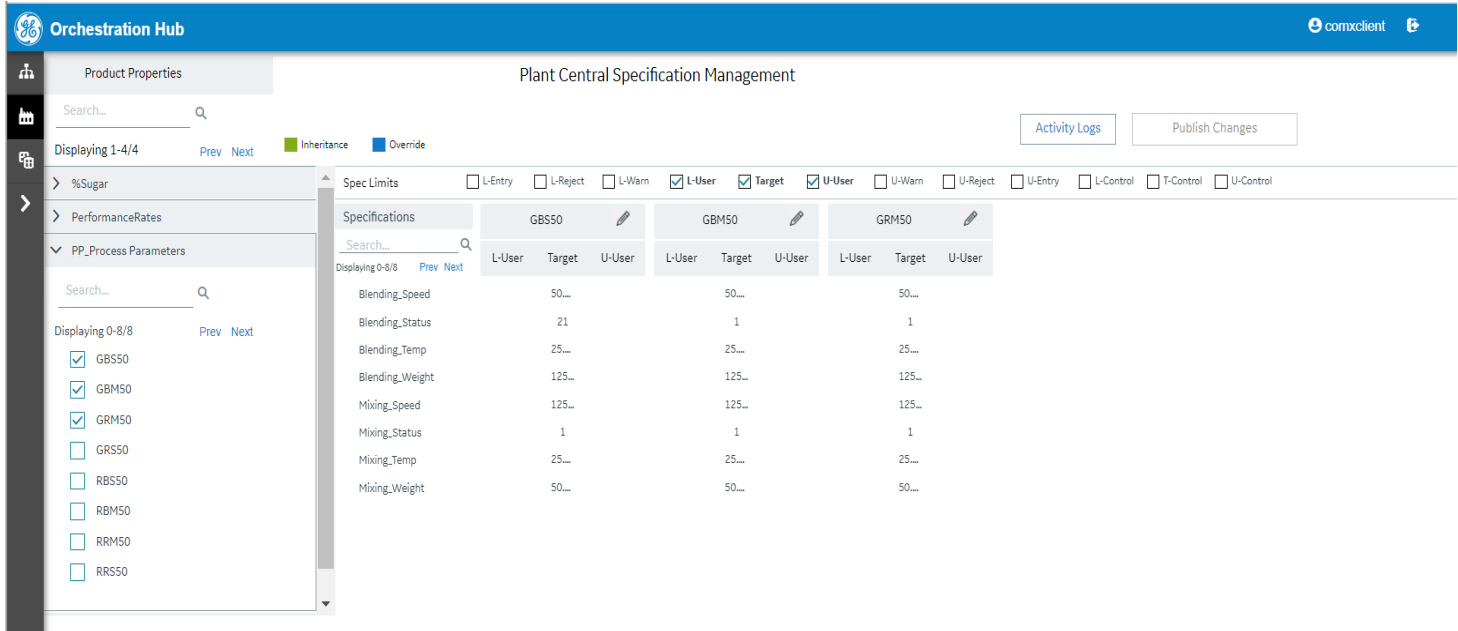

Step 4

You can click on any of the specification values to see detailed information in the Property Panel in the right side.

The screenshot shows the 'Plant Central Specification Management' interface. On the left, a navigation pane shows 'PerformanceRates' expanded, with 'GBM50' selected. The main area displays a table of specifications for GBM50. The 'Blending(Kg/hr)' specification is highlighted, and its value '101.00' is visible. On the right, the 'Property Panel' provides detailed information for the selected specification, including its name 'Blending(Kg/hr)', its value '101.00', and a comment 'comment1'.

Specifications	GBM50	GBM50	GRM50						
	L-User	Target	U-User	L-User	Target	U-User	L-User	Target	U-User
Blending(Kg/hr)	110...	10...	100...						
Case_Packing(Case...	100...	100...	100...						
Filling(Tubes/Hr)	100...	100...	100...						
Labelling(Tubes/Hr)	100...	100...	100...						
Mixing(Kg/hr)	100...	100...	100...						
Tube_Packing(Tube...	100...	100...	100...						

Step 5

You can click on the History in the Property Panel to see all past transactions/updates for that value.

The screenshot shows the same interface as Step 4, but with a 'History' dialog box open. The dialog box displays a table of transactions for the 'Blending(Kg/hr)' specification. The table has columns for 'User Name', 'Date', 'Comment', 'Change', and 'Application'. The first row shows a transaction by 'comxclient' on '2022-06-29 06:2...' with a comment of 'comment1' and an application of 'Orc Hub'.

Characteristic	Spec Limit	Spec Name	Spec Value	
GBM50	Target	Blending(Kg/hr)	101.00	
User Name	Date	Comment	Change	Application
comxclient	2022-06-29 06:2...	comment1	101.00	Orc Hub

Step 6

You can click the pencil icon to enter Edit Mode for the respective characteristics and update the values.

The screenshot shows the 'Plant Central Specification Management' interface. The left sidebar displays a tree view with 'PerformanceRates' expanded and 'PP_Process Parameters' selected. A list of parameters is shown, with GBSS0, GBM50, and GRM50 checked. The main area displays a table of specifications for three character names: GBSS0, GBM50, and GRM50. The table has columns for L-User, Target, and U-User. The 'Blending_Speed' row shows a value of 50.00 for GBM50. A pencil icon is visible next to the GBM50 header, indicating edit mode. The right sidebar shows a 'Property Panel' for 'Blending_Speed' with a 'Spec Value' of 50.00 and a 'Last Modified Date' of 2022-06-27 11:43:12.587.

Specifications	GBSS0	GBM50	GRM50						
	L-User	Target	U-User	L-User	Target	U-User	L-User	Target	U-User
Blending_Speed		50...		50.00				50...	
Blending_Status		21		1				1	
Blending_Temp		25...		25.00				25...	
Blending_Weight		125...		125.00				125...	
Mixing_Speed		125...		125.00				125...	
Mixing_Status		1		1				1	
Mixing_Temp		25...		25.00				25...	
Mixing_Weight		50...		50.00				50...	

Step 7

After updating the values, click on the tick icon to add Comments for the changes made. After all the comments are entered click the Save button to proceed.

The screenshot shows the 'Plant Central Specification Management' interface with an 'Add Comments' dialog box open. The dialog box has a table with columns for Char Name, Spec Name, Spec Limit, Spec Value, and Comment. The table contains one row for GBM50 with a Spec Name of 'Blending(Kg/hr)', a Spec Limit of 'Target', and a Spec Value of '101.00'. The Comment field contains 'comment!'. The dialog box has 'Cancel' and 'Save' buttons.

Char Name	Spec Name	Spec Limit	Spec Value	Comment
GBM50	Blending(Kg/hr)	Target	101.00	comment!

Step 8

If e-signature is configured , e-signature pop will be opened :

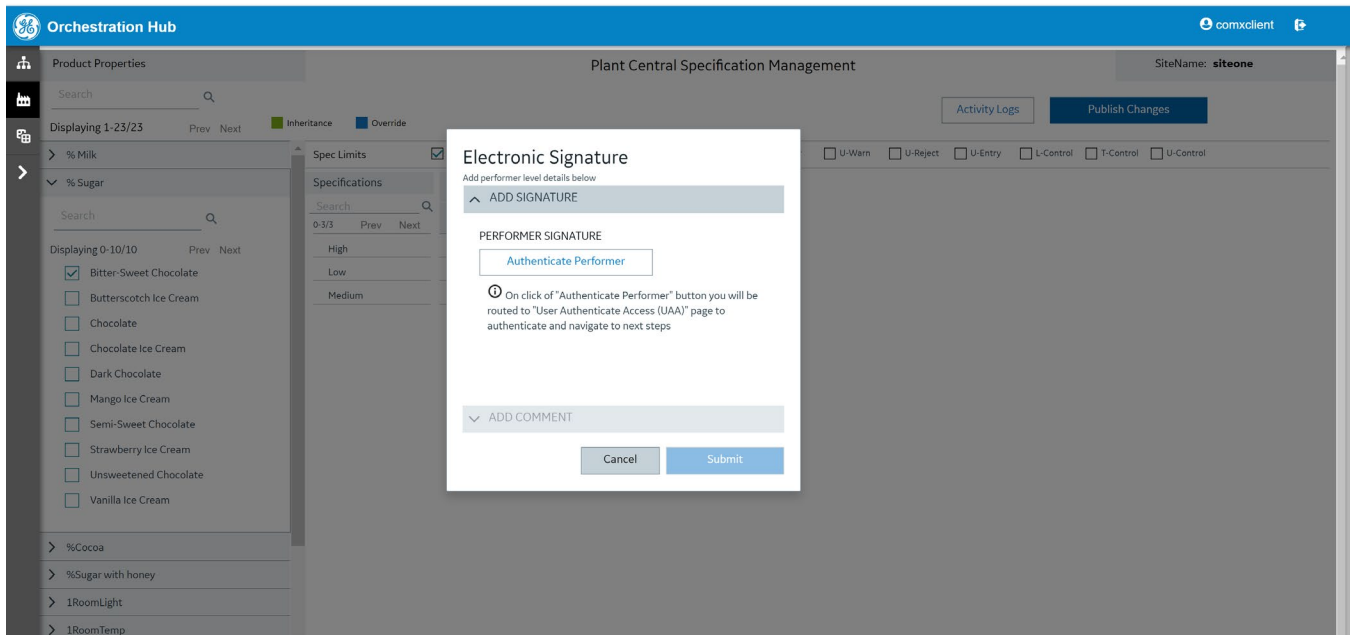

Step 9

Click on Authenticate Performer and give correct credentials to do e-signature . It will take you back to original page .

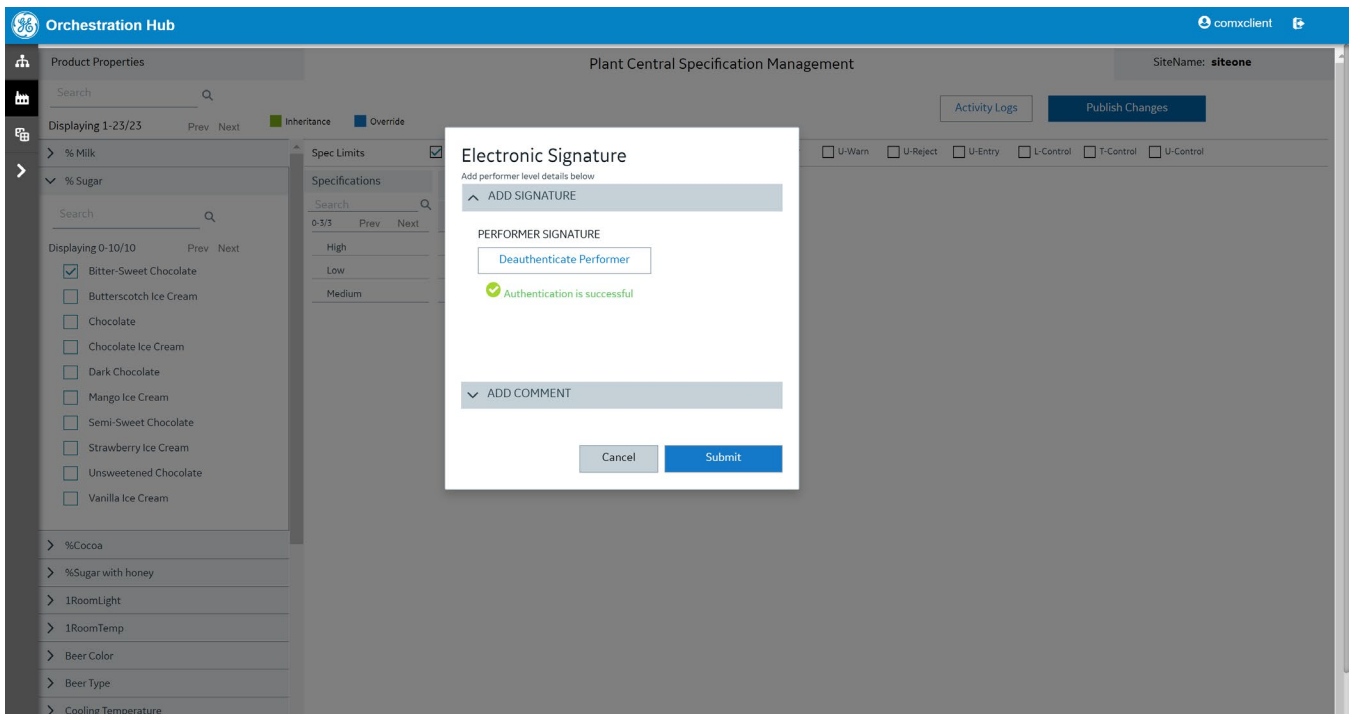
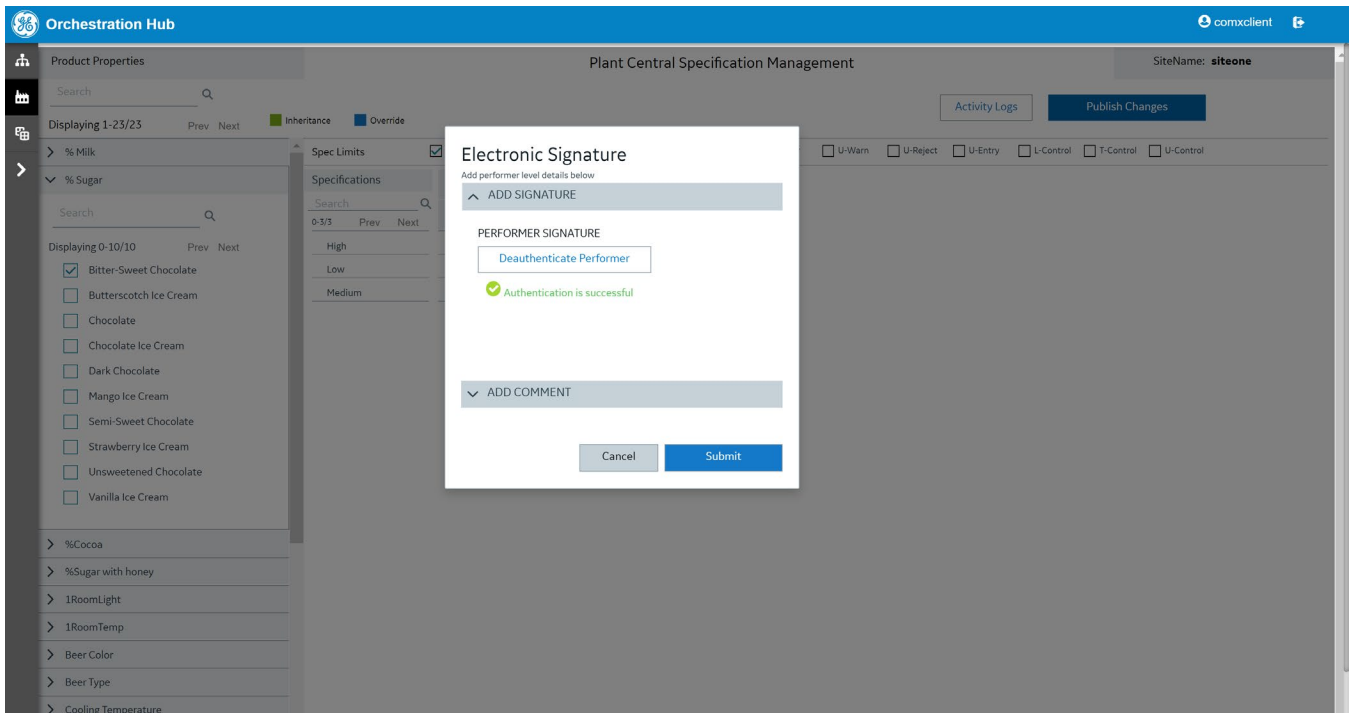

Step 10

After the comments for the changes are entered, you can now click the Publish Changes button to publish the changes. A dialog box to confirm the changes appears. Click the Yes, Publish button.

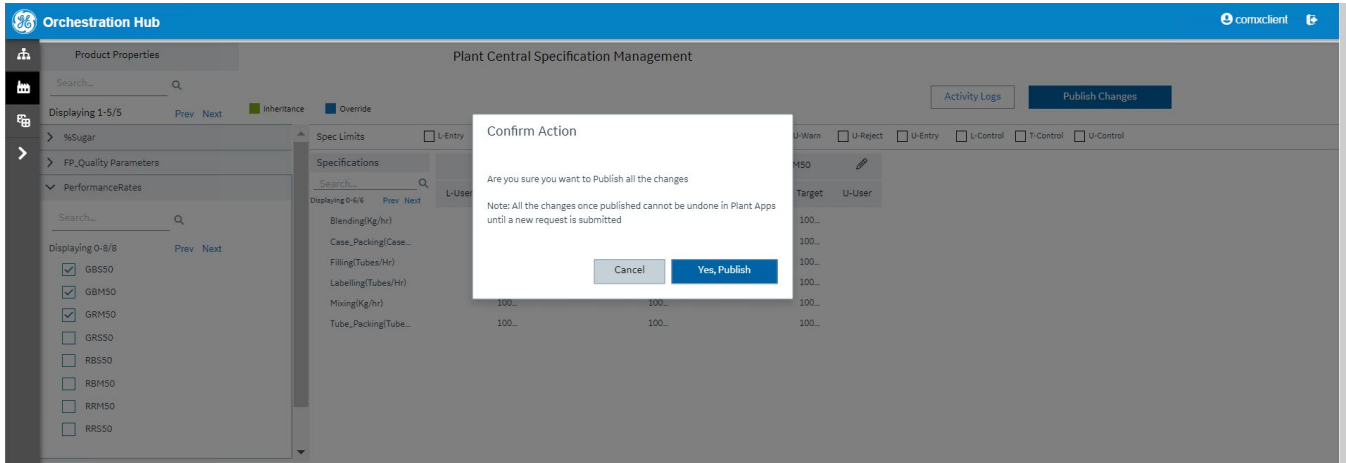

Step 11

After the Publish button is clicked, a message appears saying “Successfully published changes to Plant Application.” This means that the values are updated in Plant Applications.

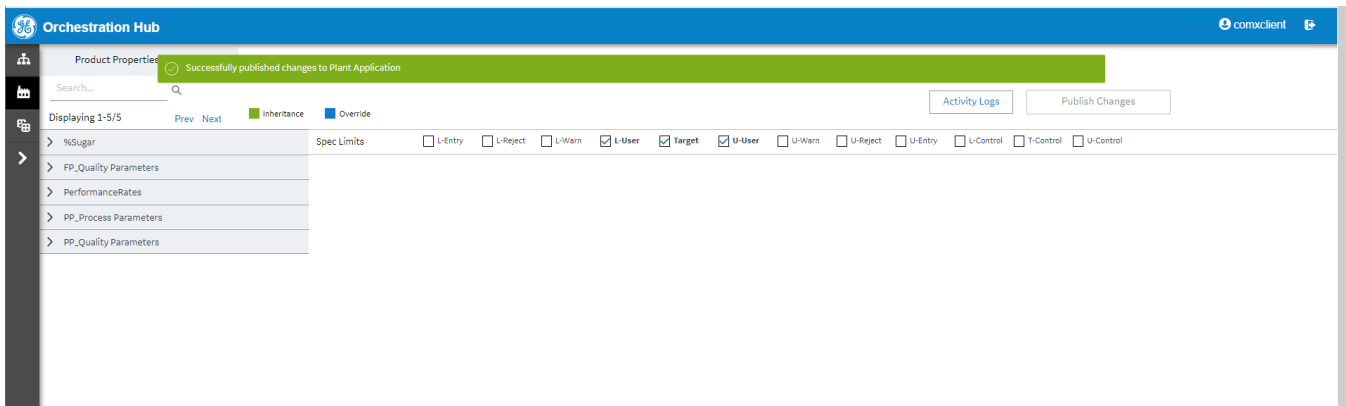

Step 12

After publishing the updates, you can see all the updates/changes made in Activity log.

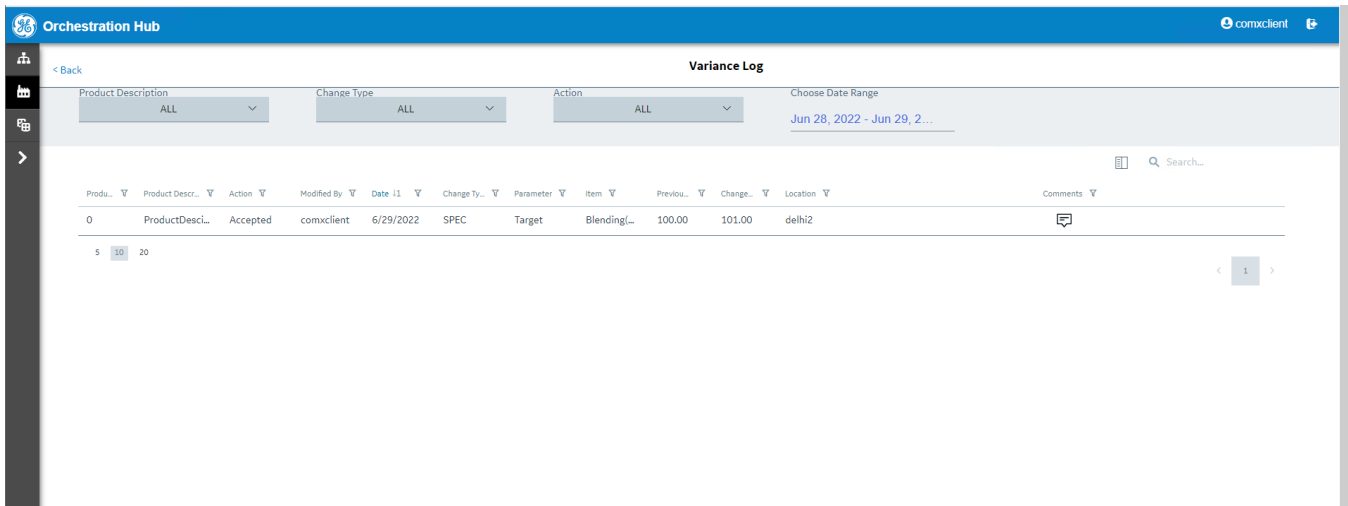

Variance Management Flow

Step 1

Select Variance Management in the Left Navigation Menu to enter the Variance Management Application.

After you enter the Application, you will see All Updates/Changes made in Orchestration Hub based in the date range selected. By default, it's selected as the previous date to current date.

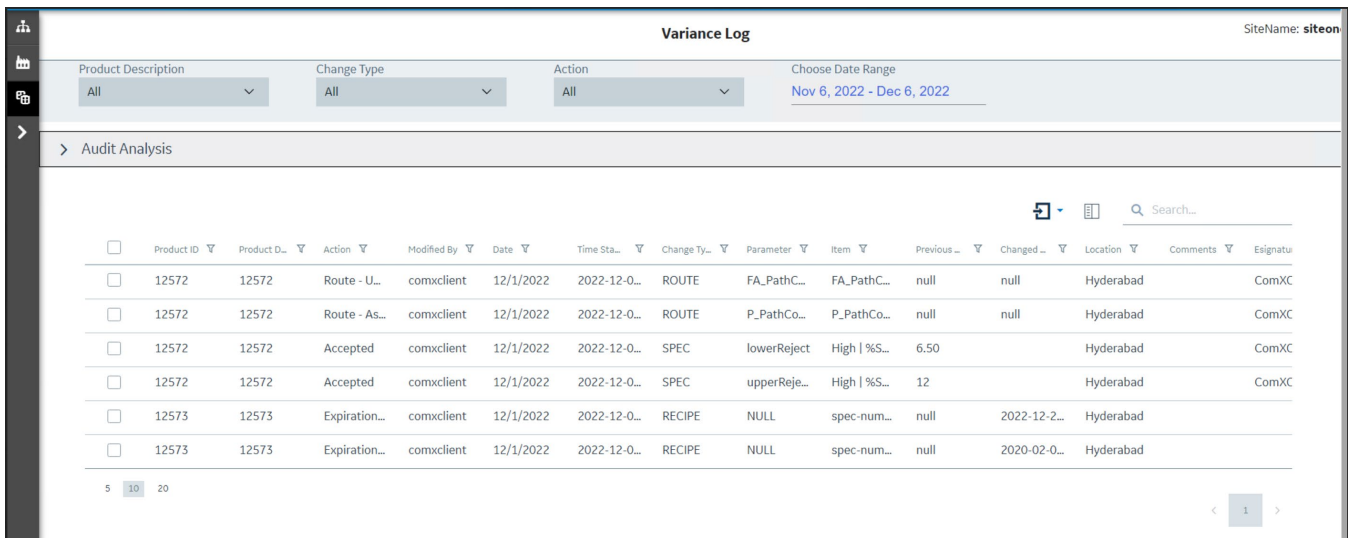

Step 2

User can see the respective audit information in two forms :

1. Grid data
2. Charting representation

You can select the required Product Description, Change Type (Spec / Recipe / New Product/Route), Action (Accepted/Rejected/Expiration Update/Add/New BOM-Created/New BOM-Rejected/Route-Assigned/Route/Unassigned) and the date to see the respective audit information in both grid and charting .

Step 3:

To view data in charts format, user needs to expand accordion for “Audit Analysis”, through which user will be able to see the data in different tabs .

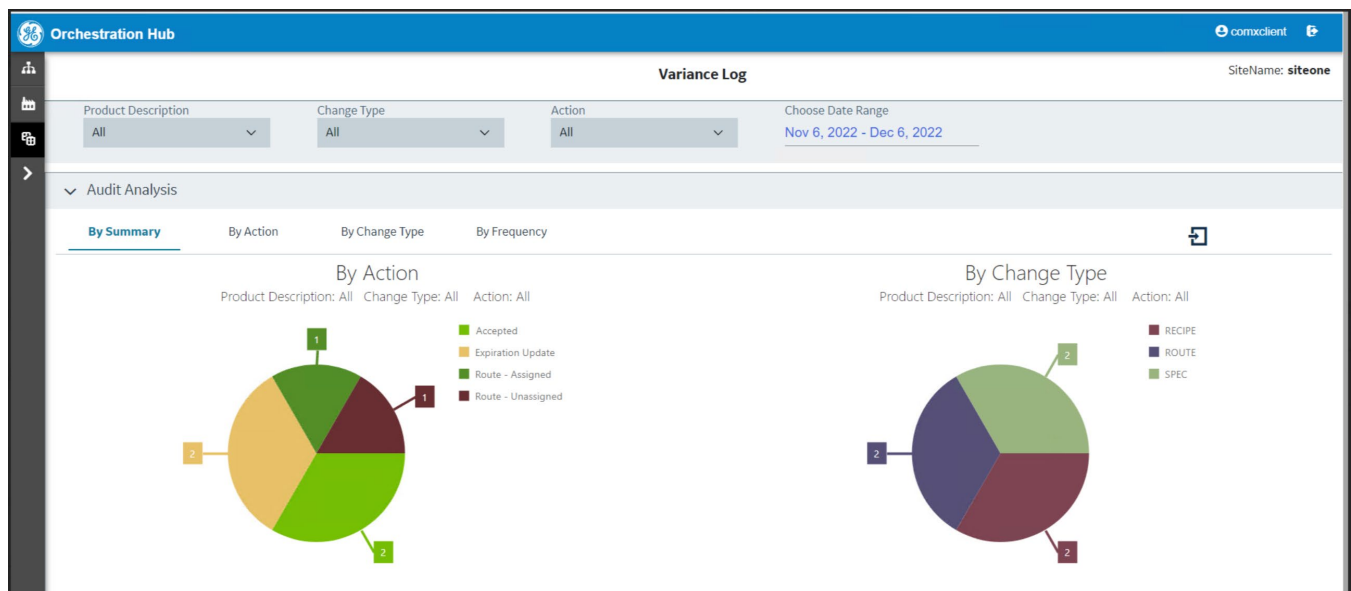

Step 4:

1. **Summary:** User will be able to see an overview of total number changes. Summary tab consist of following two pie charts by Action and by Change Type.
 By Action: Overview of all the changes with respect to Action field.
 By Change Type: Overview of all the changes with respect to Change Type field.
2. **By Action:** User will be able to see the data in form of bar charts based on the total actions performed in Enterprise connect / Plant connect.
 This tab will also include a range selector directly below chart which provide zooming and panning functionality for large set of data.

Default number of products on X axis for large number of data is 10. For analyzing more data on chart use range selector provided.

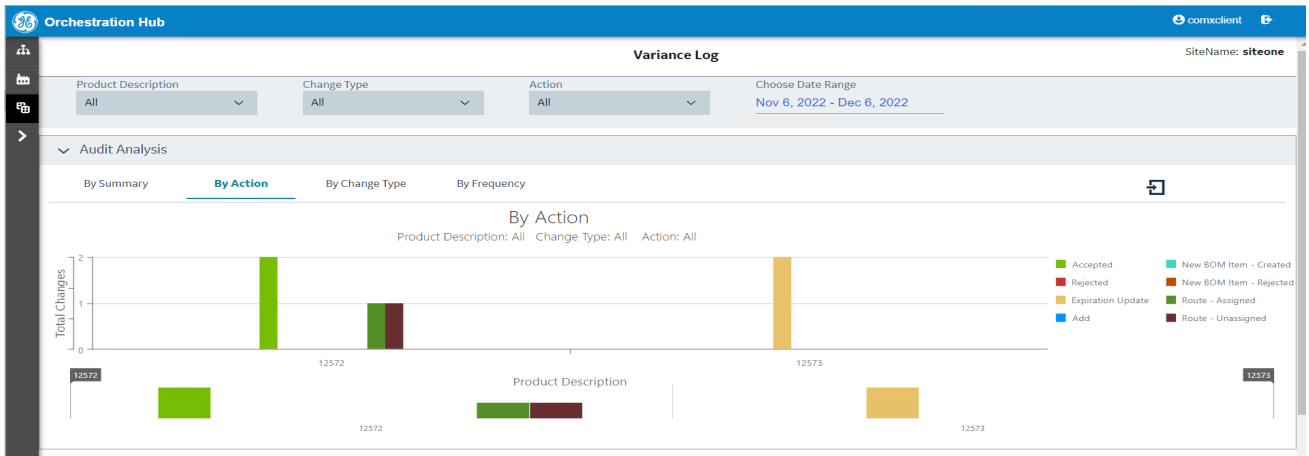

- Change Type:** User will be able to see the total actions performs based on Change Type Enterprise connect / Plant connect. This tab will also include a range selector directly below chart which provide zooming and panning functionality for large set of data. Default number of products on X axis for large number of data is 10. For analyzing more data on chart use range selector provided.

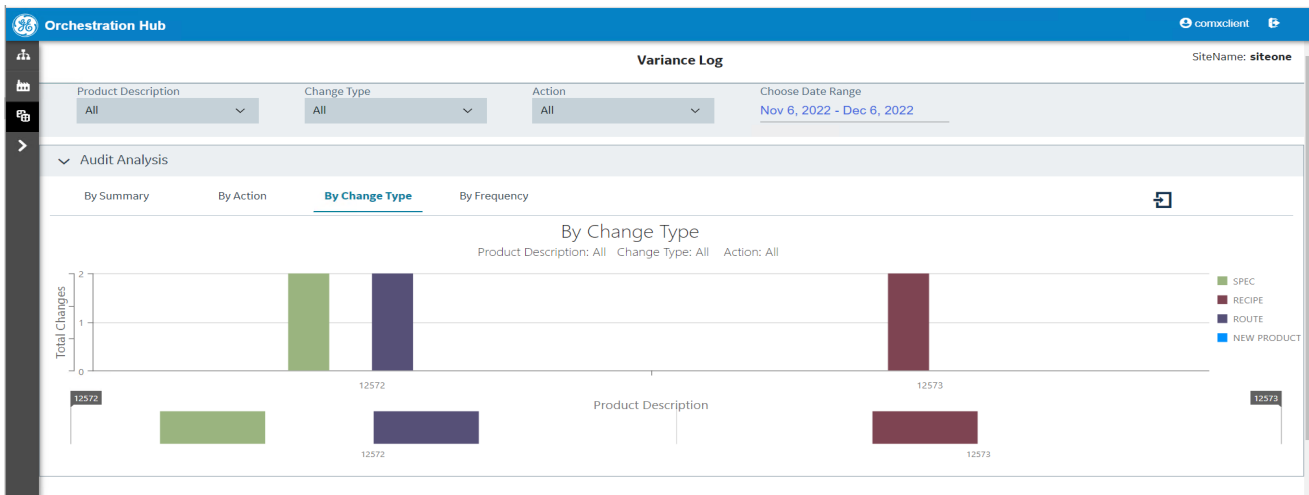

- Frequency:** User will be able to see the frequency at which actions are performed on specification based on date. This tab will also include a range selector directly below chart which provide zooming and panning functionality for large set of data.

Default number of products on X axis for large number of data is 10. For analyzing more data on chart use range selector provided.

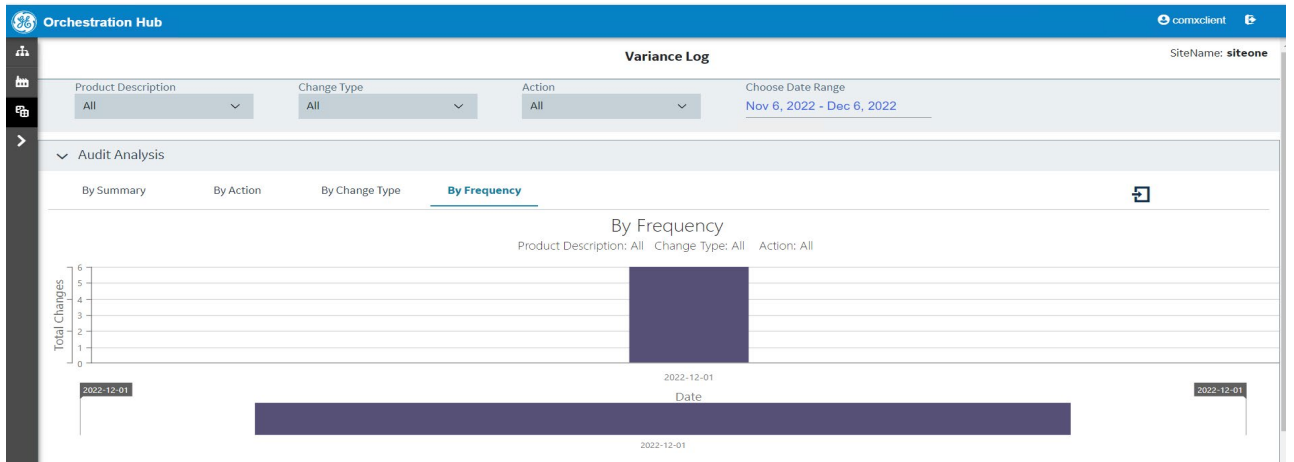

5. User can always export any of the charts from export icon in pdf form.

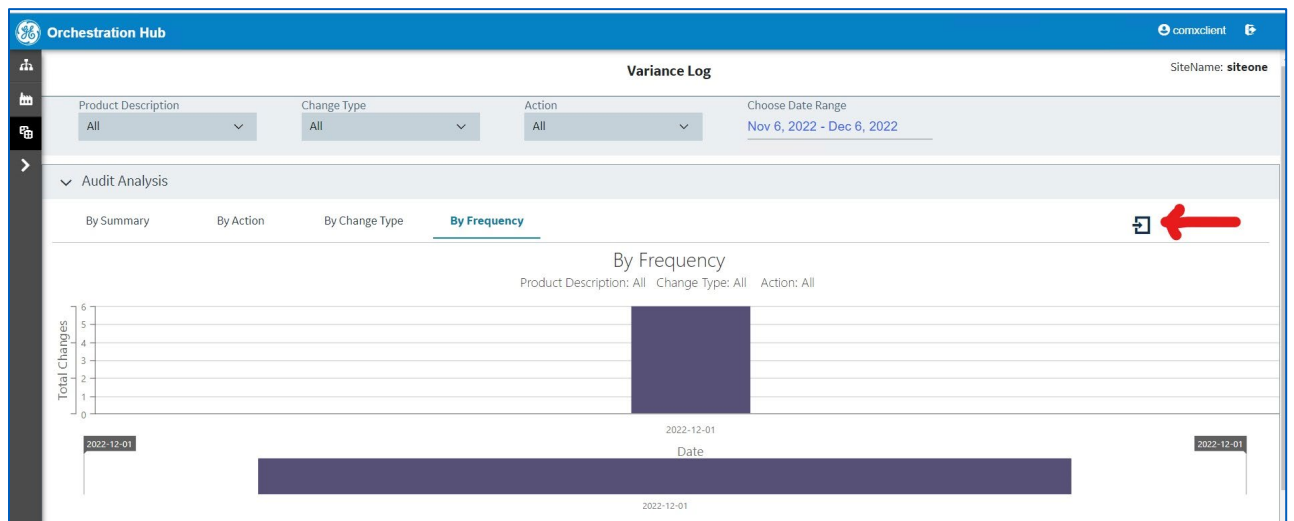

Customization of Column Names

Step 1

To Customize the column Headers of any application.

The screenshot shows the GE Digital Orchestration Hub interface. The top navigation bar includes the GE logo, 'Orchestration Hub', 'comxclient', and 'SiteName: siteone'. The main content area displays a table of product updates under the 'Product Updates (16)' section. The table has the following columns: STATUS, CHANGE TYPE, PRODUCT FAMILY, PRODUCT, PRODUCT ID, LOCATION, and ACTION. A red box highlights the column headers. The table contains 10 rows of data, all with a status of 'Approved' and a location of 'Hyderabad'. Each row has a 'Review' button in the ACTION column.

STATUS	CHANGE TYPE	PRODUCT FAMILY	PRODUCT	PRODUCT ID	LOCATION	ACTION
Approved	Recipe/Spec	External-Product	12572	12572	Hyderabad	Review
Approved	Spec	External-Product	156757	156757	Hyderabad	Review
Approved	Spec	External-Product	830111	830111	Hyderabad	Review
Approved	Spec	External-Product	764567	764567	Hyderabad	Review
Approved	Spec	External-Product	830004	830004	Hyderabad	Review
Approved	Spec	External-Product	830020	830020	Hyderabad	Review
Approved	Spec	External-Product	101	101	Hyderabad	Review
Approved	Spec	External-Product	830126	830126	Hyderabad	Review
Approved	Spec	External-Product	830599	830599	Hyderabad	Review

Navigate to the base folder where Orchestration Hub is installed and open Customization JSON File from respective app folder “GE Digital\OrchestrationHub\NodeUIApp\product-orchestration-app-1.0.0.0\assets”. You will see JSON like below

```
customization.json
1 {
2   "enterpriseConnect":{
3     "newProductColumns":{
4       {
5         "colName": "STATUS",
6         "alterName": "STATUS",
7         "cellTemplate":"cellTemplateStatus"
8       },
9       {
10        "colName": "CHANGE TYPE",
11        "alterName": "CHANGE TYPE",
12        "cellTemplate":"cellTemplateSpecType"
13      },
14      {
15        "colName": "PRODUCT",
16        "alterName": "PRODUCT",
17        "dataField": "specshortname"
18      },
19      {
20        "colName": "LOCATION",
21        "alterName": "LOCATION",
22        "dataField": "businessunits"
23      },
24      {
25        "colName": "PRODUCT FAMILY",
26        "alterName": "PRODUCT FAMILY",
27        "cellTemplate":"ProductFamilyTemplate"
28      },
29      {
30        "colName": "ACTION",
31        "alterName": "ACTION",
32        "cellTemplate":"newProductTemplate"
33      }
34    },
35    "expirationColumns":[
36      {
37
```

Here

- “colName” is the default name of the column which is visible on the UI.
- “alterName” is customizable.
- “dataField” is the id of the column.
- “cellTemplate” is the template id.

Step 2

You can customize the column name in “alterName” and save the file. It should be visible in the respective application column header once you refresh the browser window

Note: User should only change “alterName” to customize respective column names and should not change any other variables as it would affect the application.

Localization

Our applications support translation to English Japanese, Chinese and German languages.

We pick default language from your browser and our application shows up in the same language.

Note: As we are customizing column names, column headers are not translatable. User can specify the column header in desired language in customization JSON.



About GE

GE (NYSE: GE) is the world's Digital Industrial Company, transforming industry with software-defined machines and solutions that are connected, responsive and predictive. GE is organized around a global exchange of knowledge, the "GE Store," through which each business shares and accesses the same technology, markets, structure and intellect. Each invention further fuels innovation and application across our industrial sectors. With people, services, technology and scale, GE delivers better outcomes for customers by speaking the language of industry.